

Installation, Operation and Maintenance Manual

Please read and save these instructions for future reference. Read carefully before attempting to assemble, install, operate or maintain the product described. Protect yourself and others by observing all safety information. Failure to comply with these instructions will result in voiding of the product warranty and may result in personal injury and/or property damage.

Technical Support
 Call 1-800-789-8550



General Safety Information

⚠ DANGER

Always disconnect power before working on or near a unit. Lock and tag the disconnect switch or breaker to prevent accidental power up.

⚠ CAUTION

When servicing the unit, motor may be hot enough to cause pain or injury. Allow motor to cool before servicing.

⚠ IMPORTANT

All factory provided lifting lugs must be used when lifting any unit. Failure to comply with this safety precaution could result in property damage, serious injury or death.

⚠ WARNING

Disconnect all electrical power to the fan and secure to the "OFF" position prior to inspection or servicing. Failure to comply with this safety precaution could result in serious injury or death.

⚠ WARNING

Improper installation, adjustment, alteration, service or maintenance can cause property damage, injury or death. Read the installation, operating and maintenance instructions thoroughly before installing or servicing this equipment.

⚠ FOR YOUR SAFETY

This appliance is not intended for use by persons (including children) with reduced physical, sensory or mental capabilities, or lack of experience and knowledge, unless they have been given supervision or instruction concerning use of the appliance by a person responsible for their safety. Children should be supervised to ensure that they do not play with the appliance.

⚠ FOR YOUR SAFETY

MAXIMUM ALTITUDE: 11154 FT OR 3400 M

General Safety Information

Only qualified personnel should install this system. Personnel should have a clear understanding of these instructions and should be aware of general safety precautions. Improper installation can result in electric shock, possible injury due to coming in contact with moving parts, as well as other potential hazards. Other considerations may be required if high winds or seismic activity are present. If more information is needed, contact a licensed professional engineer before moving forward.

1. Follow all local electrical and safety codes, as well as the National Electrical Code (NEC), the National Fire Protection Agency (NFPA), where applicable. Follow the Canadian Electric Code (CEC) in Canada.
2. All moving parts must be free to rotate without striking or rubbing any stationary objects.
3. Unit must be securely and adequately grounded.
4. Do not spin fan wheel faster than maximum cataloged fan RPM. Adjustments to fan speed significantly effects motor load. If the fan RPM is changed, the motor current should be checked to make sure it is not exceeding the motor nameplate amps.
5. Do not allow the power cable to kink or come in contact with oil, grease, hot surfaces or chemicals. Replace cord immediately if damaged.
6. Verify that the power source is compatible with the equipment.
7. Never open access doors to the unit while it is running.

Table of Contents

Unit Overview	3
Receiving, Handling and Storage	4
Model Number Code.	5
Installation	6
Optional Component Overview	9
Pre Start-Up Check11
Start-Up Components12
Optional Start-Up Component13
Start-Up14
Routine Maintenance15
Troubleshooting - Unit17
Maintenance Log.18
Our Commitment.	Backcover

Unit Overview

Summer Operation

Outdoor air is preconditioned (temperature and moisture levels are decreased) by the transfer of energy from the cooler, drier exhaust air via the energy recovery wheel. The preconditioned air is typically mixed with return air going back to the air handler for final conditioning.

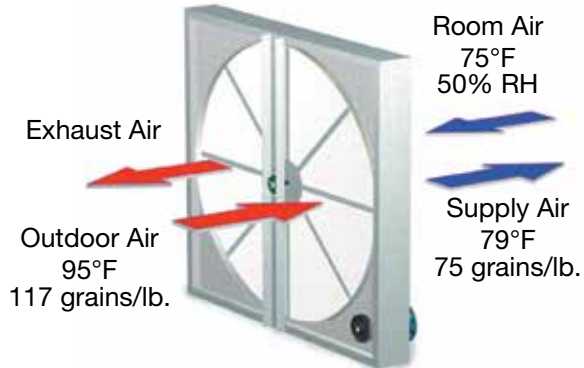

Winter Operation

Outdoor air is preconditioned (temperature and moisture levels are increased) by the transfer of energy from the warmer, more humid exhaust air via the energy recovery wheel. The preconditioned air is typically mixed with return air going back to the air handler for final conditioning.

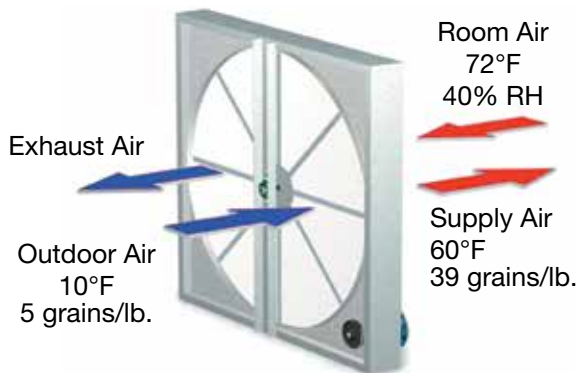

Receiving

This product may have been subject to road salt during transit. If so, immediately wash off all visible white residue from all exterior surfaces. Upon receiving the product, check to ensure all items are accounted for by referencing the delivery receipt or packing list. Inspect each crate or carton for shipping damage before accepting delivery. Alert the carrier if any damage is detected, **do not refuse shipment**. The customer shall make notation of damage (or shortage of items) on the delivery receipt and all copies of the bill of lading which should be countersigned by the delivering carrier. If damaged, immediately contact your manufacturer's representative. Any physical damage to the unit after acceptance is not the responsibility of the manufacturer.

Handling

Units are to be rigged and moved by the lifting brackets provided or by the skid when a forklift is used. Location of brackets varies by model and size. Handle in such a manner as to keep from scratching or chipping the coating. Damaged finish may reduce ability of unit to resist corrosion.

Unpacking

Verify that all required parts and the correct quantity of each item have been received. If any items are missing, report shortages to your local representative to arrange for obtaining missing parts. Sometimes it is not possible that all items for the unit be shipped together due to availability of transportation and truck space. Confirmation of shipment(s) must be limited to only items on the bill of lading.

Storage

Units are protected against damage during shipment. If the unit cannot be installed and operated immediately, precautions need to be taken to prevent deterioration of the unit during storage. The user assumes responsibility of the unit and accessories while in storage. The manufacturer will not be responsible for damage during storage. These suggestions are provided solely as a convenience to the user.

The ideal environment for the storage of units and accessories is indoors, above grade, in a low humidity atmosphere which is sealed to prevent the entry of blowing dust, rain, or snow. Units designed for outdoor applications may be stored outdoors. All accessories must be stored indoors in a clean, dry atmosphere.

Indoor

Do not store outdoors or in a wet location. This unit is intended for indoor use only. Improper storage which results in damage to the product will void the warranty. Maintain temperatures evenly to prevent condensation. Remove any accumulations of dirt, water, ice, or snow and wipe dry before moving to indoor storage. To

avoid condensation, allow cold parts to reach room temperature. Leave coverings loose to permit air circulation and to allow for periodic inspection.

The unit should be stored at least 3½ in. (89 mm) off the floor. Clearance should be provided to permit air circulation and space for inspection.

Inspection and Maintenance

While in storage, inspect units once per month. Keep a record of inspection and maintenance performed.

If moisture or dirt accumulations are found on parts, the source should be located and eliminated. At each inspection, rotate the fan wheel by hand ten to fifteen revolutions to distribute lubricant on motor. If paint deterioration begins, consideration should be given to touch-up or repainting. Units with special coatings may require special techniques for touch-up or repair.

Machined parts coated with rust preventive should be restored to good condition promptly if signs of rust occur. Immediately remove the original rust preventive coating with petroleum solvent and clean with lint-free cloths. Polish any remaining rust from surface with crocus cloth or fine emery paper and oil. Do not destroy the continuity of the surfaces. Wipe thoroughly clean with Tectyl® 506 (Ashland Inc.) or the equivalent. For hard to reach internal surfaces or for occasional use, consider using Tectyl® 511M Rust Preventive, WD-40® or the equivalent.

Removing from Storage

As units are removed from storage to be installed in their final location, they should be protected and maintained in a similar fashion until the equipment goes into operation.

Prior to installing the unit and system components, inspect the unit assembly to make sure it is in working order.

1. Check all fasteners, set screws on the fan, wheel, bearings, drive, motor base, and accessories for tightness.
2. Rotate the fan wheel(s) by hand and assure no parts are rubbing.

General

Model Number Code

The model number code provides basic identification of the unit. The serial number can be used by the manufacturer's representative or the factory to identify the specific unit configuration. The serial number of the unit must be provided when consulting the manufacturer's representative or the factory.

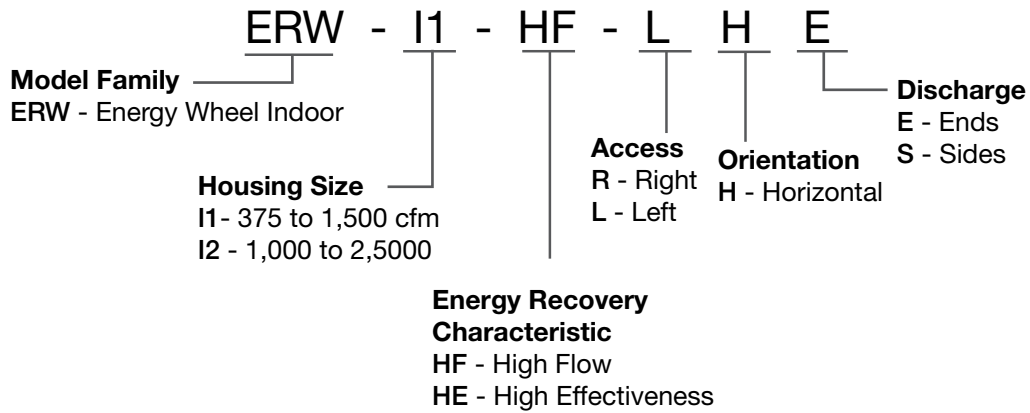

RANGE OF EXTERNAL STATIC PRESSURES: 0.00 - 4.00 IN.W.C. OR 0.000 - 0.995 KPA

Installation - This unit is suitable for INDOOR installation ONLY

Service Clearances

ERW-I units require minimum clearances to perform routine maintenance, such as filter replacement, energy wheel cassette inspection, and fan inspection. Blower and motor assemblies, energy recovery wheel cassette and filter sections are always provided with a service door or panel for proper component access.

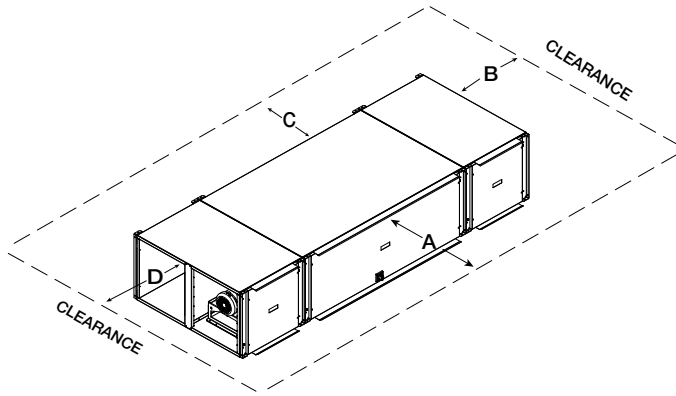

Recommended Service Clearances				
Housing	A	B	C	D
1	35	0	0	0
2	41	0	0	0

All dimensions are in inches.

Ductwork

Recommended Discharge Duct Size	
Housing	Duct Size (in.)
1	15 x 16
2	18 x 21

Recommended duct sizes are only intended to be a guide and may not satisfy the requirements of the project. Refer to plans for appropriate job specific duct size and/or velocity limitations. Attach ducts to the unit with flexible adapters to isolate the ductwork from any possible vibration. Follow good duct practices for all ductwork. Install ductwork in accordance with SMACNA and AMCA guidelines, NFPA 96 and local codes.

Combustible Clearances

Combustible Clearances				
	Floor	Top	Sides	Ends
Insulated Units	0 inches (0 mm)	0 inches (0 mm)	0 inches (0 mm)	0 inches (0 mm)

Clearance to combustibles is defined as the minimum distance required between the heater and adjacent combustible surfaces to ensure the adjacent surface's temperature does not exceed 90 degrees above the ambient temperature.

Handling

While this unit was constructed with quality and dependability in mind, damage still may occur during handling of the unit for installation. Exercise extreme caution to prevent any damage from occurring to the refrigerant system.

The system design and installation should follow accepted industry practice, such as described in the ASHRAE Handbook. Adequate space should be left around the unit for piping coils and drains, filter replacement, and maintenance. Sufficient space should be provided on the side of the unit for routine service and component removal should that become necessary.

Lifting

WARNING

All factory provided lifting lugs must be used when lifting the unit. Failure to comply with this safety precaution could result in property damage, serious injury or death.

1. Before lifting, be sure that all shipping material has been removed from unit.
2. To assist in determining rigging requirements, refer to the submittal for unit weights.
3. Each individual module must be supported when lifting the unit.
4. Rigger to use suitable mating hardware to attach to unit corner lifting points.
5. If the unit is hoisted, use spreader bars to prevent damage to the unit by the lifting cables.
6. Always test-lift the unit to check for proper balance and rigging before hoisting to desired location.
7. Install all doors when handling the unit to prevent damage.

Installation - This unit is suitable for INDOOR installation ONLY

Hanging Instructions

The unit should be hung by the factory supplied mounting brackets. The mounting brackets can be attached to the top or bottom of the unit. There should be a minimum of (8) mounting points per unit. The mounting points should line up on the opposing side to evenly support the unit. The unit can be supported from the bottom and “trapeze mounted”. When trapeze mounting the unit, there should be a minimum of (8) mounting points per unit. Refer to the submittal for unit weights. Always mount the unit level to ensure proper operation

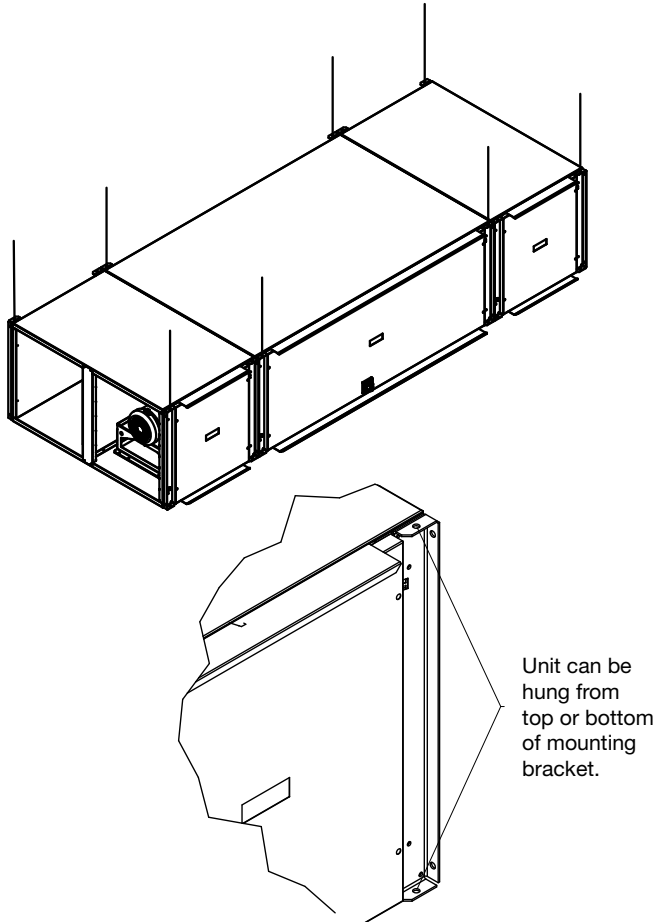

Floor Mounting

Mount the unit on a level and dry surface with adequate support under each module. Fasten the unit using appropriate methods. The installer is responsible for determining appropriate support and fastening methods to ensure compliance with all applicable codes.

Installation of Electrical Wiring

⚠ WARNING

To prevent injury or death due to electrocution or contact with moving parts, lock disconnect switch in the off position.

⚠ IMPORTANT

Before connecting power to the unit, read and understand the following instructions and wiring diagrams. Complete wiring diagrams are attached on the inside of the control center door(s).

⚠ IMPORTANT

All wiring should be done in accordance with the latest edition of the National Electric Code ANSI/NFPA 70 and any local codes that may apply. In Canada, wiring should be done in accordance with the Canadian Electrical Code.

⚠ IMPORTANT

The equipment must be properly grounded. Any wiring running through the unit in the airstream must be secured and protected from sharp edges.

⚠ CAUTION

If replacement wire is required, it must have a temperature rating of at least 105°C, except for an energy cut-off or sensor lead wire which must be rated to 150°C.

⚠ DANGER

High voltage electrical input is needed for this equipment. This work should be performed by a qualified electrician.

⚠ CAUTION

Any wiring deviations may result in personal injury or property damage. Manufacturer is not responsible for any damage to, or failure of the unit caused by incorrect final wiring.

⚠ IMPORTANT

Manufacturer's standard control voltage is 24 VAC. Control wire resistance should not exceed 0.75 ohms (approximately 285 feet total length for 14 gauge wire; 455 feet total length for 12 gauge wire). If the resistance exceeds 0.75 ohms, an industrial-style plug-in relay should be wired in place of the remote switch. The relay must be rated for at least 5 amps and have a 24 VAC coil. Failure to comply with these guidelines may cause motor starters to chatter or not pull in, resulting in contactor failures and/or motor failures.

Installation - This unit is suitable for INDOOR installation ONLY

1. Determine the Size of the Main Power Lines.

The unit's nameplate states the voltage and the unit's MCA. The main power lines to the unit should be sized accordingly. The nameplate is located on the outside of the unit on the control panel side.

2. Provide the Opening(s) for the Electrical Connection.

Electrical openings vary by unit size and arrangement and are field-supplied.

3. Connect the Main Power.

Connect the main power lines to the disconnect switch and main grounding lug(s). Torque field connections to 20 in.-lbs.

Effect of Low Voltage on Wattage and British Thermal Unit (BTU)

The heating elements may be used on voltages lower than the design voltage of the heater, however, the wattage and BTU output will be reduced to the percentages listed in the table below.

Derated Wattage For Low Voltage					
Heater Voltage	Line Voltage	% of Heater Wattage and BTU	Heater Voltage	Line Voltage	% of Heater Wattage and BTU
480	460	92	208	200	92
	440	84		190	83
277	265	92	120	115	92
	254	84		110	84
240	230	92			
	220	84			
	208	75			
	200	69			

Typical Control Center Components

1. Microprocessor Controller
2. Relays
3. Dirty Filter Pressure Switches
4. Low Voltage Terminals
5. Energy Recovery Wheel VFD
6. 24 VAC Control Transformer
7. Current Switch
8. Distribution Block

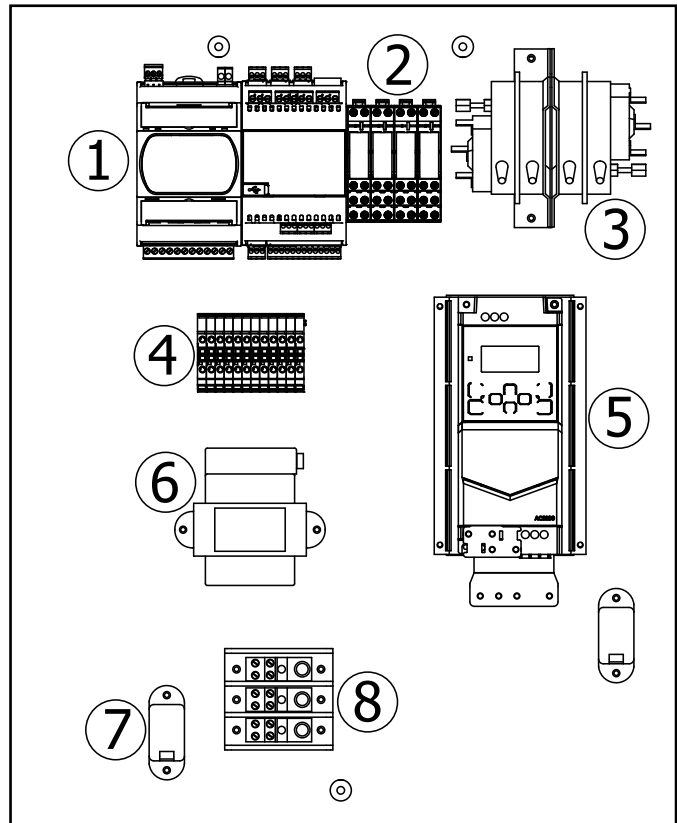

Optional Component Overview

Electric Heater

Factory installed electric heaters can be provided for preheat frost control. An electric preheater warms the outdoor air prior to the energy recovery device to prevent frosting.

Preheaters: Preheaters are standard as single-stage on/off control. Preheaters are single point wired at the factory. A thermodisc temperature sensor (with a 5°F set point) is mounted in the outdoor airstream after the preheater to turn the preheater on. See Frost Control Application/Operation for typical set points. If the temperature falls below the set point and the wheel pressure drop sensor is triggered, the preheater will turn on.

Access to the preheater control panel is through the outdoor air filter door.

Economizer

The energy wheel operation can be altered to take advantage of economizer operation (free cooling). Available modes are:

1. Stop wheel
2. Modulating wheel
3. Exhaust only operation

Stop wheel: A field-supplied call for cool is required. De-energizing the wheel is accomplished one of three ways:

1. The outdoor air temperature is less than the outdoor dry bulb set point (DRYBLB SET)
2. The outdoor air temperature is less than the return air temperature
3. The outdoor air enthalpy is within the preset enthalpy curve

Effectively, the two sensors create a deadband where the energy recovery wheel will not operate and free cooling from outside can be brought into the building unconditioned.

Modulating wheel (factory): A variable frequency drive is fully programmed at the factory. A “call for cool” must be field wired to the unit (terminals provided in unit-refer to wiring diagram in unit control center) to allow for initiation of economizer mode. The unit recognizes economizer conditions based one of the previously mention sensors and set points. The unit will then modulate the wheel speed to maintain the mixed air temperature set point (MAT SET).

Modulating wheel (by others): A variable frequency drive is fully programmed at the factory. A field-supplied 0-10 VDC signal will be required for operation of the energy wheel. The field will be required to have full control of the energy wheel speed at all times. If no 0-10 VDC signal is provided, the energy wheel will run at the factory default of 3 Hz and no energy transfer will be captured.

Exhaust only operation: The unit will have the capability to receive an external signal to power the supply fan on/off.

Frost Control

Extremely cold outdoor air temperatures can cause moisture condensation and frosting on the energy recovery wheel. Frost control is an optional feature that will prevent/control wheel frosting. Available options are:

1. Timed exhaust
2. Electric preheat
3. Modulating wheel

All of these options are provided with a thermodisc mounted in the outdoor air intake compartment and a pressure sensor to monitor pressure drop across the energy wheel.

An outdoor air temperature of below 5°F and an increase in pressure drop would indicate that frost is occurring. Both the pressure sensor and the outdoor air thermodisc must trigger in order to initiate frost control. The two sensors together ensure that frost control is only initiated during a real frost condition.

Timed exhaust frost control includes a timer in addition to the thermodisc and wheel pressure sensor. When timed exhaust frost control is initiated, the timer will turn the supply blower off. Time exhaust using default timer setting will shut down the supply fan for 5 minutes every 30 minutes to allow exhaust to defrost energy wheel. Use the test procedure in the Optional Start-Up Accessories section for troubleshooting.

Electric preheat frost control includes an electric heater (at outdoor air intake) in addition to the thermodisc and pressure sensor on wheel. When electric preheat frost control is initiated, the electric preheater will turn on and warm the air entering the energy wheel to avoid frosting. Use the test procedure in the Optional Start-Up Accessories section for troubleshooting.

Modulating wheel frost control includes a variable frequency drive (VFD) in addition to the thermodisc and pressure sensor. When modulating wheel frost control is initiated, the VFD will reduce the speed of the wheel. Reducing the speed of the energy wheel reduces its effectiveness, which keeps the exhaust air condition from reaching saturation, thus, eliminating condensation and frosting. If the outdoor air temperature is greater than the frost threshold temperature OR the pressure differential is less than the set point, the wheel will run at full speed. If the outdoor air temperature is less than 5°F AND the pressure differential is greater than the set point, the wheel will run at reduced speed until the pressure differential falls below the set point. The VFD will be fully programmed at the factory.

Optional Component Overview

Rotation Sensor

The rotation sensor monitors energy wheel rotation. If the wheel should stop rotating, the sensor will close a set of contacts in the unit control center.

Dirty Filter Sensor

Dirty filter sensors monitor pressure drop across the outdoor air filters, exhaust air filters, or both. If the pressure drop across the filters exceeds the set point, the sensor will close a set of contacts in the unit control center. Field-wiring of a light (or other alarm) to these contacts will notify maintenance personnel when filters need to be replaced. The switch has not been set at the factory due to external system losses that will affect the switch. This switch will need minor field adjustments after the unit has been installed with all ductwork complete. The dirty filter switch is mounted in the exhaust inlet compartment next to the unit control center or in unit control center.

Dampers

Motorized outdoor air and exhaust air dampers are optional and are factory mounted and wired.

Pre Start-Up Check

⚠ DANGER

Electric shock hazard. Can cause injury or death. Before attempting to perform any service or maintenance, turn the electrical power to unit to OFF at disconnect switch(es). Unit may have multiple power supplies.

⚠ WARNING

Use caution when removing access panels or other unit components, especially while standing on a ladder or other potentially unsteady base. Access panels and unit components can be heavy and serious injury may occur.

Do not operate energy recovery ventilator without the filters and birdscreens installed. They prevent the entry of foreign objects such as leaves, birds, etc.

⚠ CAUTION

Do not run unit during construction phase. Damage to internal components may result and void warranty.

- Rotate the fan wheels and energy recovery wheels by hand and ensure no parts are rubbing. If rubbing occurs, refer to Start-Up section for more information.
- Filters can load up with dirt during building construction. Replace any dirty pleated filters and clean the aluminum mesh filters in the intake hood. Refer to Routine Maintenance section.
- Check the tightness of all factory wiring connections.
- Verify control wire gauge. Refer to the Electrical Connections section.
- Verify diameter seal settings on the energy recovery wheel. Refer to Start-Up section for more information.

General Start-Up Information

Every installation requires a comprehensive start-up to ensure proper operation of the unit. As part of that process, the following checklist must be completed and information recorded. Starting up the unit in accordance with this checklist will not only ensure proper operation, but will also provide valuable information to personnel performing future maintenance. Should an issue arise which requires factory assistance, this completed document will allow unit experts to provide quicker resolve. Qualified personnel should perform start-up to ensure safe and proper practices are followed.

Unit Model Number _____
(e.g. ERW-I2)

Unit Serial Number _____
(e.g. 10111000)

Energy Wheel Date Code _____
(e.g. 0450)

Start-Up Date _____

Start-Up Personnel Name _____

Start-Up Company _____

Phone Number _____

Pre Start-Up Checklist – check as items are completed.

- Disconnect and lock-out all power switches
- Remove any foreign objects that are located in the energy recovery unit.
- Check all fasteners, set-screws, and locking collars on the fans, bearings, drives, motor bases and accessories for tightness.

Start-Up Components

Fan

The fan should be checked for free rotation. If any binding occurs, check for concealed damage and foreign objects in the fan housing.

⚠ CAUTION

When operating conditions of the fan are to be changed (speed, pressure, temperature, etc.), consult manufacturer to determine if the unit can operate safely at the new conditions.

Supply/Exhaust Fan (Plenum Type)

The unit contains one or two plenum supply fans located on the end(s) of the unit. Efficient fan performance can be maintained by having the correct offset.

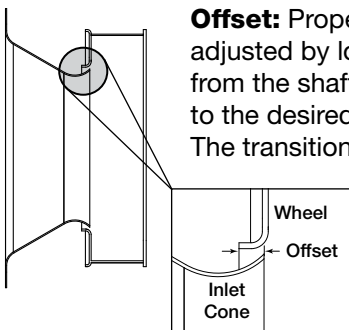

Offset: Proper offset, or overlap, is adjusted by loosening the wheel hub from the shaft and moving the wheel to the desired position along the shaft. The transition between the inlet cone and the wheel should be as shown; there is a smooth feel to the profile when moving one component to the other.

Housing Size	Offset (inches)	Tolerance (inches)
1	.10	± 1/32
2	.12	± 1/32

Refer to the respective Installation, Operation and Maintenance Manual shipped with this unit for additional start-up and maintenance information regarding the plenum fan.

Supply/Exhaust Fan Wheel Rotation Direction

Check for proper wheel rotation by momentarily energizing the fan. Rotation is determined by viewing the wheel from the drive side and should match the rotation decal affixed to the fan housing.

If the wheel is rotating the wrong way, direction can only be reversed by changing the motor program. Check for unusual noise, vibration or overheating of the bearings. Refer to the Troubleshooting portion of this manual if a problem develops.

Supply/Exhaust Fan Speed

Fan speed is controlled by the microprocessor controller. Motor speed will be set by changing the speed setting in the microprocessor controller during the unit Test and Balance. Always check the motor amperage rating shown on the motor

nameplate when changing the fan RPM. All access doors must be installed except the control center door.

Vibration

Excessive vibration may be experienced during initial start-up. Left unchecked, excessive vibration can cause a multitude of problems, including structural and/or component failure. The most common sources of vibration are listed.

Wheel Unbalance
Mechanical Looseness
Poor Inlet/Outlet Conditions
Foundation Stiffness

Many of these conditions can be discovered by careful observation. Refer to the Troubleshooting

section of this manual for corrective actions. If observation cannot locate the source of vibration, a qualified technician using vibration analysis equipment should be consulted. If the problem is wheel unbalance, in-place balancing can be done.

Generally, fan vibration and noise is transmitted to other parts of the building by the ductwork. To eliminate this undesirable effect, the use of flexible duct connectors is recommended.

Energy Recovery Wheel

The ERW-I model that contain a total energy recovery wheel are inspected for proper mechanical operation at the factory. However, during shipping and handling, shifting can occur that may affect wheel operation. The wheel is accessible through the access door marked "Energy Wheel Cassette Access".

Turn the energy recovery wheels by hand to verify free operation. The wheel should rotate smoothly and should not wobble.

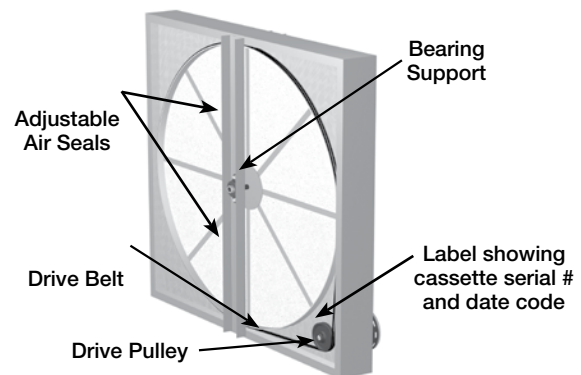

Start-Up Components

Drive Belt

Inspect the drive belt. Make sure the belt rides smoothly through the pulley and over the wheel rim.

Air Seals

Check that the air seals located around the outside of the wheel and across the center (both sides of wheel) are secure and in good condition. Air seal clearance is determined by placing a sheet of paper, to act as a feeler gauge, against the wheel face. To access seals, follow the instructions in the Energy Recovery Wheel Maintenance section. To adjust the air seals, loosen all eight seal retaining screws. These screws are located on the bearing support that spans the length of the cassette through the wheel center. Tighten the screws so the air seals tug slightly on the sheet of paper.

Replace cassette into unit, plug in wheel drive, replace access door and apply power. Observe by opening door slightly (remove filters if necessary to view wheel) the wheel should rotate freely at about 20-40 RPM.

Optional Start-Up Component

Dirty Filter Switch

To adjust the switch, the unit must be running with all of the access doors in place, except for the

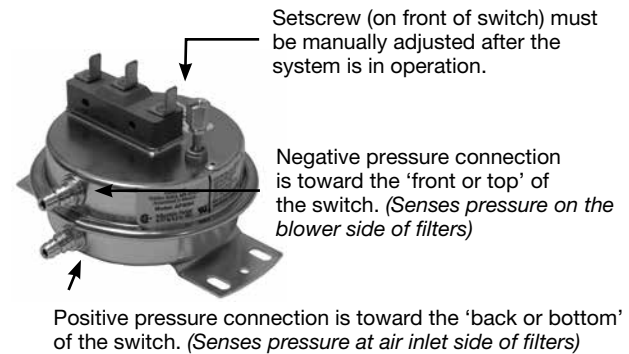

compartment where the switch is located (exhaust intake compartment). The adjusting screw is located on the top of the switch.

1. Open the filter compartment and place a sheet of plastic or cardboard over 50% of the filter media.
2. Replace the filter compartment door.
3. Check to see if there is power at the alert signal leads (refer to electrical diagram).
4. Whether there is power or not, turn the adjustment screw on the dirty filter gauge (clockwise if you did not have power, counterclockwise if you did have power) until the power comes on or just before the power goes off.
5. Open the filter compartment and remove the obstructing material.
6. Replace the door and check to make sure that you do **not** have power at the alert signal leads.

The unit is now ready for operation.

Start-Up

SPECIAL TOOLS REQUIRED

- Voltage Meter (with wire probes)
- Amperage Meter
- Thermometer
- Tachometer
- Incline manometer or equivalent

Start-Up Checklist

The unit will be in operational mode during start-up. Use necessary precautions to avoid injury. All data must be collected while the unit is running. In order to measure volts and amps, the control center door must be open, and the unit energized using a crescent wrench to turn the disconnect handle.

Check line voltage at unit disconnect

_____ L1-L2 volts
_____ L2-L3 volts
_____ L1-L3 volts

Motor Amp Draw

• Supply Fan	_____ L1 amps	• Exhaust Fan	_____ L1 amps
	_____ L2 amps		_____ L2 amps
	_____ L3 amps		_____ L3 amps
• Energy Wheel			
	_____ L1 amps		
	_____ L2 amps		
	_____ L3 amps		

Fan RPM

_____ Supply Fan _____ Exhaust Fan

Correct fan rotation direction

Supply Fan	Yes / No
Exhaust Fan	Yes / No

Routine Maintenance

⚠ DANGER

Electric shock hazard. Can cause injury or death. Before attempting to perform any service or maintenance, turn the electrical power to unit to OFF at disconnect switch(es). Unit may have multiple power supplies.

⚠ CAUTION

Use caution when removing access panels or other unit components, especially while standing on a ladder or other potentially unsteady base. Access panels and unit components can be heavy and serious injury may occur.

Once the unit has been put into operation, a routine maintenance program should be set up to preserve reliability and performance. Items to be included in this program are:

Lubrication

Apply lubrication where required

Dampers

Check for unobstructed operation

Motors

Check for cleanliness

Blower Wheel & Fasteners

Check for cleanliness
Check all fasteners for tightness
Check for fatigue, corrosion, wear

Bearings

Check for cleanliness
Check set screws for tightness
Lubricate as required

External Filter

Check for cleanliness - clean if required

Internal Filter

Check for cleanliness - replace if required

Door Seal

Check if intact and pliable

Energy Recovery Wheel

Check for cleanliness - clean if required
Check belt for wear
Check pulley, bearings, and motor

Maintenance Procedures:

Lubrication

Check all moving components for proper lubrication. Apply lubrication where required. Any components showing excessive wear should be replaced to maintain the integrity of the unit and ensure proper operation.

Routine Maintenance

Dampers

Check all dampers to ensure they open and close properly and without binding. Backdraft dampers can be checked by hand to determine if blades open and close freely. Apply power to motorized dampers to ensure the actuator opens and closes the damper as designed.

Fan Motors

Motor maintenance is generally limited to cleaning and lubrication. Cleaning should be limited to exterior surfaces only. Removing dust and grease buildup on the motor housing assists proper motor cooling. Never wash-down motor with high pressure spray. Greasing of motors is only intended when fittings are provided. Many fractional motors are permanently lubricated for life and require no further lubrication.

Fan Wheel & Fasteners

Wheels require very little attention when moving clean air. Occasionally oil and dust may accumulate on the wheel causing imbalance. When this occurs, the wheel and housing should be cleaned to assure smooth and safe operation. Inspect fan impeller and housing for fatigue, corrosion or wear.

Routinely check all fasteners, set screws and locking collars on the fan, bearings, drive, motor base and accessories for tightness. A proper maintenance program will help preserve the performance and reliability designed into the fan.

Bearings

Most bearings are permanently lubricated and require no further lubrication under normal use. Normal use being considered -20°F to 120°F and in a relatively clean environment. Some bearings are relubricatable and will need to be regreased depending on fan use. Check your bearings for grease zerk fittings to find out what type of bearing you have. If your fan is not being operated under normal use, bearings should be checked monthly for lubrication.

Internal Filter Maintenance

Units are always provided with 2-inch, pleated filters in the outdoor air and exhaust airstreams. These filters should be checked per a routine maintenance schedule and replaced as necessary to ensure proper airflow through the unit. See table for pleated filter size and quantity for each unit. Replacement filters shall be of same performance and quality as factory installed filters. Filter type must be pleated design with integral metal grid.

Pleated Filter Size and Quantities				
Housing	Supply		Exhaust	
	Size	Qty	Size	Qty
1	16 x 16	2	16 x 16	2
2	18 x 20	2	18 x 20	2

All dimensions in inches.

Outdoor Air Filters: Access to the outdoor air filters is through the door labeled as “Filter Access” on the outdoor air side of the unit.

Exhaust Air Filters: Access to the exhaust air filters is through the door labeled as “Filter Access” on the exhaust air side of the unit.

Refer to Access Door Descriptions section for additional information on filter locations.

Door Seal Maintenance

Stick-on type seal is installed on the door. Inspect at least annually to ensure that seal is still pliable and intact.

Energy Recovery Wheel Maintenance

Annual inspection of the energy recovery wheel is recommended. Units ventilating smoking lounges and other non-clean air spaces should have energy recovery wheel inspections more often based upon need. Inspections for smoke ventilation applications are recommended bimonthly to quarterly until a regular schedule can be established.

Accessing the Energy Recovery Wheel

Disconnect power to the unit. Open door labeled “Energy Wheel Cassette Access”.

Unplug the wheel drive motor.

Pull the wheel cassette halfway out.

Removing the Energy Recovery Wheel Segments (stainless steel rim)

Steel retainers are located on the inside of the wheel rim. Push the retainer towards the center of the wheel, then lift up and away to release segments.

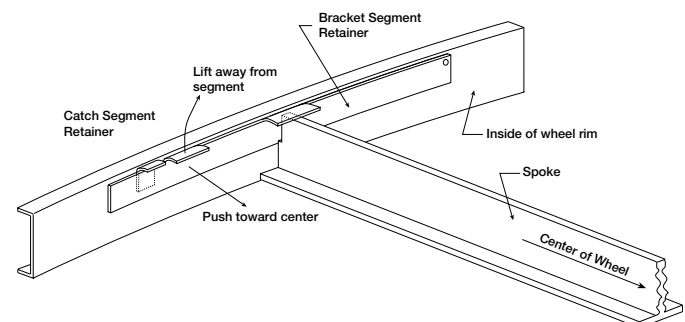

Routine Maintenance

⚠ IMPORTANT

Place retainers back in the original position before rotating the energy recovery wheel, otherwise damage to retainer will occur.



Wheel segment removed

Cleaning the Energy Recovery Wheel

If the wheel appears excessively dirty, it should be cleaned to ensure maximum operating efficiency. Only excessive buildup of foreign material needs to be removed. Discoloration and staining of energy recovery wheel does not affect its performance.

Thoroughly spray wheel matrix with household cleaner such as Fantastik® or equivalent. Gently rinse with warm water and using a soft brush remove any heavier accumulation. A detergent/water solution can also be used. Avoid aggressive organic solvents, such as acetone. The energy recovery wheel segments can be soaked in the above solution overnight for stubborn dirt or accumulation.

After cleaning is complete, shake the excess water from the wheel or segments. Dry wheel or segments before placing them back into the cassette. Place wheel or segments back into cassette by reversing removal procedures.

⚠ CAUTION

Do not clean energy recovery wheel segments with water in excess of 140°F (60°C).

Do not dry energy recovery wheel segments in air in excess of 140°F (60°C).

The use of a pressure washer to clean segments is **not recommended**. Damage could result.

Energy Recovery Wheel Belt

Inspect belts each time filters are replaced. Belts that look chewed up or are leaving belt dust near the motor pulley may indicate a problem with the wheel. Be sure to inspect wheel for smooth and unrestricted rotation. If a belt requires replacement, contact the local Valent representative. Instructions for replacement will ship with the new belt.



Wheel Belt & Pulley

Energy Recovery Wheel Bearing

In the unlikely event that a wheel bearing fails, the bearing is behind a removable plate on the wheel support beam. Contact the local Valent representative for detailed instructions on how to replace the bearing.

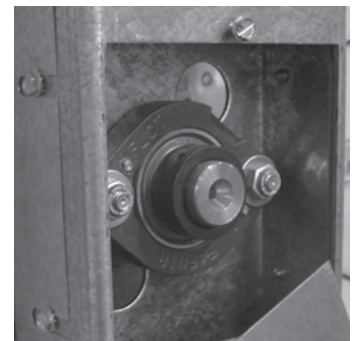

Wheel Bearing

Troubleshooting – Unit

Symptom	Possible Cause	Corrective Action
Blower fails to operate	Blown fuse or open circuit breaker.	Replace fuse or reset circuit breaker and check amps.
	Defective motor	Replace.
	Motor overloaded.	“See below”
	Electrical.	Check for On/Off switches. Check for correct supply voltage.
Motor over amps	CFM too high.	Check cfm and adjust drives if needed.
	Static pressures are higher or lower than design.	If higher, ductwork should be improved. If lower, fan rpm should be lower.
	Blower rotation is incorrect.	Check rotation and reverse if necessary.
	Motor voltage incorrect.	Check motor nameplate versus supplied voltage.
	Motor horsepower too low.	See specifications and catalog for fan curves to determine if horsepower is sufficient.
	Shorted windings in motor.	Replace motor.
Low airflow (cfm)	Unit damper not fully open.	Adjust damper linkage or replace damper motor.
	System static pressure too high.	Improve ductwork to eliminate losses using good duct practices.
	Blower speed too low.	Check fan wheel rpm with catalog data and adjust if necessary.
	Fan wheels are operating backwards.	Check rotation and reverse if necessary.
	Dirty filter or energy wheel.	Follow cleaning procedures in Routine Maintenance section.
	Leaks in ductwork.	Repair.
	Elbows or other obstructions may be obstructing fan outlet.	Correct or improve ductwork.
High airflow (cfm)	Blower fan speed too high.	Check for correct fan rpm. Decrease fan speed if necessary.
	Filter(s) not in place.	Install filters.
	Insufficient static pressure (Ps) (airflow resistance).	Induce Ps into system ductwork. Make sure grilles and access doors are installed. Decrease fan speed if necessary.
Energy wheel does NOT turn	Air seals are too tight.	See Energy Recovery Wheel under Unit Start-Up section.
	“Economizer” sensors are operating.	Adjust temperature or enthalpy set points as needed.
	No power to wheel motor.	Make sure wheel drive is plugged in. Verify power is available.
	Wheel drive belt.	Check for loose or broken belts. Replace belts (consult factory).
	VFD overload.	Compare motor amp rating to setting in VFD. Adjust accordingly.
Energy wheel runs intermittently	Wheel motor overloads are tripping, due to rubbing between wheel and air seals.	Recheck air seals, make sure they are not too tight. See Energy Recovery Wheel under Unit Start-Up Section.

Always have a completed Pre Start-Up Checklist, unit Start-Up Checklist, and Optional Accessories Checklist prior to requesting parts or service information.

Maintenance Log

Date _____ Time _____ AM/PM

Notes: _____

Date _____ Time _____ AM/PM

Notes: _____

Date _____ Time _____ AM/PM

Notes: _____

Date _____ Time _____ AM/PM

Notes: _____

Date _____ Time _____ AM/PM

Notes: _____

Date _____ Time _____ AM/PM

Notes: _____

Date _____ Time _____ AM/PM

Notes: _____

Date _____ Time _____ AM/PM

Notes: _____

Date _____ Time _____ AM/PM

Notes: _____

Date _____ Time _____ AM/PM

Notes: _____

Date _____ Time _____ AM/PM

Notes: _____

Date _____ Time _____ AM/PM

Notes: _____

This page is intentionally left blank for printing purposes

Contact Us

Technical Support and Service

800-789-8550

Valent

60–28th Avenue North
Minneapolis, MN 55411
Main: 612-877-4800

More Information

Unit Schematics

For configuration and connection questions, see the schematics that shipped with your unit. They can typically be found attached to the main control panel door.

Mechanical and Controls Manuals

Find current mechanical and controls manuals here: www.valentair.com/resources



OUTDOOR AIR EXPERTS
ROBUST DESIGNS
DEDICATED SUPPORT

valentair.com

© 2024 Valent

Continuous product improvement is a policy of Valent; therefore, product functionality and specifications are subject to change without notice.
For the most recent product information visit the product website.

Modular Dedicated Outdoor Air Unit
ERW-I Manual
Part number: 487170
Rev. 1
December 2024