

Installation, Operation and Maintenance Manual

Please read and save these instructions for future reference. Read carefully before attempting to assemble, install, operate or maintain the product described. Protect yourself and others by observing all safety information. Failure to comply with these instructions will result in voiding of the product warranty and may result in personal injury and/or property damage.

Technical Support
 Call 1-800-789-8550

General Safety Information

This instruction manual provides installation, operating, maintenance, and parts information for the ERV Controller.

WARNING

Improper installation, adjustment, alterations, service or maintenance can cause injury and property damage, as well as possible voiding of factory warranty. No person may install, operate, or maintain the ERV Controller without first being fully trained and qualified in the installation, operation and maintenance, and carefully reading and understanding the contents of this manual. If you have any questions about these instructions, contact your local representative.

Only qualified personnel should install this product. Personnel should have a clear understanding of these instructions and should be aware of general safety precautions. Improper installation can result in electric shock, possible injury due to coming in contact with moving parts, as well as other potential hazards. For more information, contact a licensed professional engineer before moving forward.

1. Follow all local electrical and safety codes, as well as the National Electrical Code (NEC) and the National Fire Protection Agency (NFPA), where applicable. Follow the Canadian Electrical Code (CEC) and ULC-S650 if installing this product in Canada.
2. Verify that the power source is compatible with the equipment

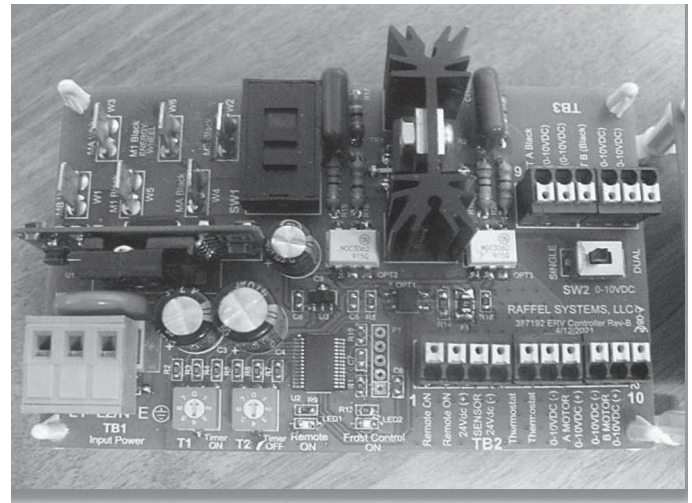

ERV Controller Features

- UL Compliance E479135.
- Simple Installation & Setup
- Wide Range 100-277Vac, 50/60 Hz Input Voltage.
- Solid State Motor Control.
- Remote ON/OFF Control Input.
- Green LED Indicator for Remote ON.
- 24Vdc @ 100mA available for Remote Sensor Power.
- Remote Thermostat Input for Frost Control.
- Adjustable ON/OFF Timers for Frost Control.
- Blue LED Indicator Frost Control.
- 0-10VDC Single or Dual Motor Speed Control Switch SW2.
- Inlet/ Outlet Motor Swap Switch SW1. Swaps Inlet and Exhaust Motors without re-wiring.

Table of Contents

General Safety Information	1
ERV Controller Features	1
Receiving, Handling, Storage	3
Control Components	3
Mounting and Wiring	4
ERV Specifications	5
Operation	5
Troubleshooting Guide	6
Maintenance Log.	7

Receiving

Upon receiving the product, check to ensure all items are accounted for by referencing the delivery receipt or packing list. Inspect each crate or carton for shipping damage before accepting delivery. Alert the carrier of any damage detected. The customer will note damage (or shortage of items) on the delivery receipt and all copies of the bill of lading which is countersigned by the delivering carrier. If damaged, immediately contact your local representative. Any physical damage to the unit after acceptance is not the responsibility of the manufacturer.

Handling

Unpacking

Verify that all required parts and the correct quantity of each item have been received. If any items are missing, report shortages to your local representative to arrange for obtaining missing parts. Sometimes it is not possible that all items for the unit be shipped together due to availability of transportation and truck space. Confirmation of shipment(s) must be limited to only items on the bill of lading.

Storage

Controls are protected against damage during shipment. If the control cannot be installed and operated immediately, precautions need to be taken to prevent deterioration of the control during storage. The user assumes responsibility of the control and accessories while in storage. The manufacturer will not be responsible for damage during storage. These suggestions provide solely as a convenience to the user.

Indoor

The ideal environment for the storage of controls and accessories is indoors, above grade, in a low humidity atmosphere that is sealed to prevent the entry of blowing dust, rain or snow. Care must be taken to protect controls and accessories from dirt, moisture, and extreme temperature during storage.

NOTE: Improper storage which results in damage to the product will void the warranty.

Control Components

Verify that all of the following parts and hardware have been received prior to beginning installation. Contact your local representative or the manufacturer if replacement parts are required.

NOTE: Additional parts (provided by others) may be required to complete the control installation, including additional wiring and hardware for mounting the control to the building structure.

NOTE: See following page for diagram of provided mounting kit and control components.

Mounting & Wiring

Hand/Off/Auto (HOA) Controller Mounting

ERV Control PCB GPN: 387192

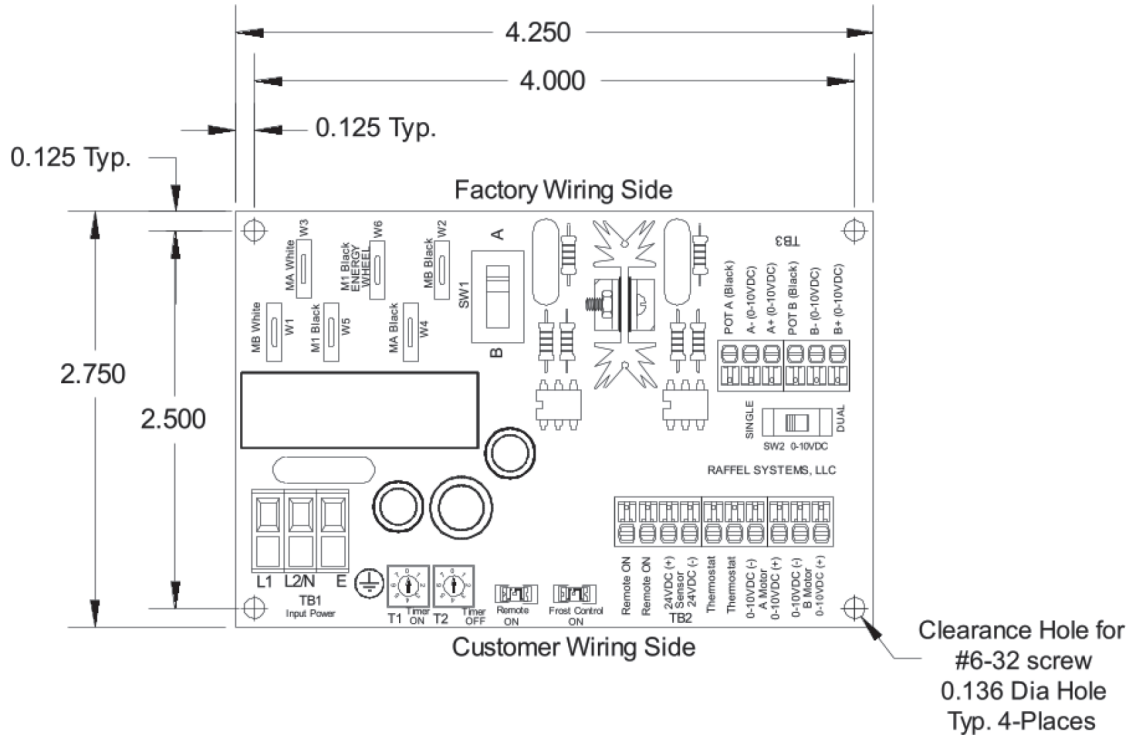

HOA Wiring

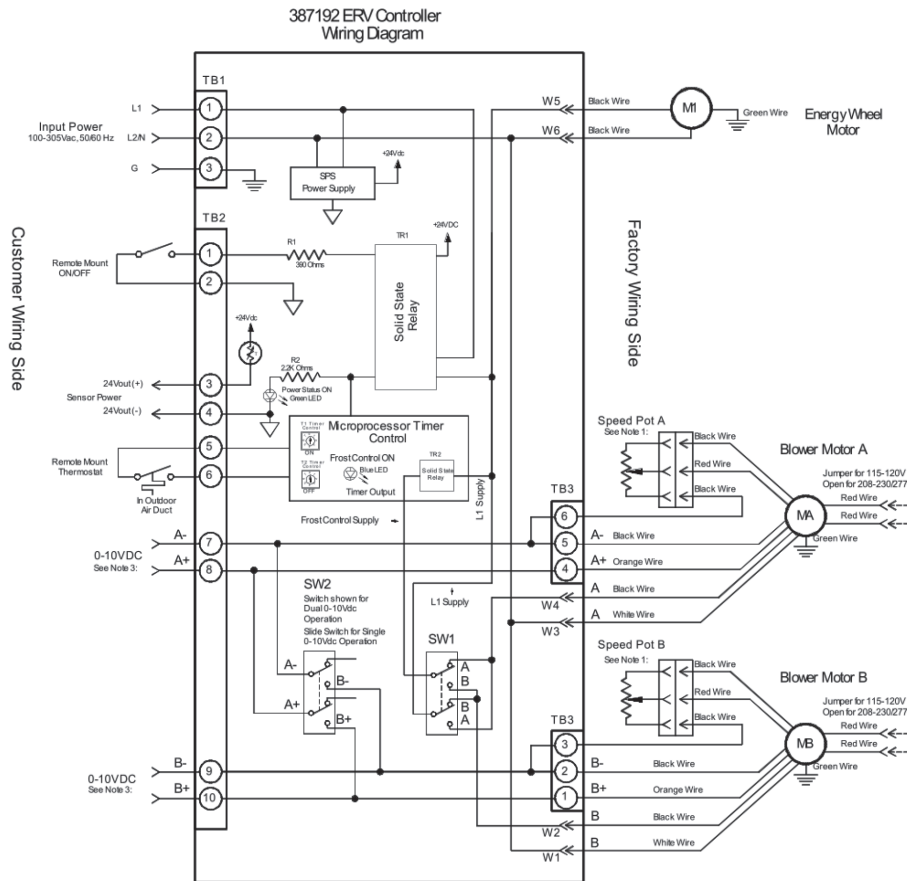

ERV Specifications

AC Input Power

1115Vac, 230Vac, 277Vac 50/60 Hz.

Motor and Aux Input

115Vac — 208Vac Input, 50/60 Hz.
230Vac — 277Vac Input, 60/60 Hz.

Motor Output

QTY (2) 115Vac 8.8FLA 3/4HP
QTY (1) Wheel Motor 115Vac 0.75 FLA

Remote ON Input

Provide a close contact between TB2-1 and TB2-2 will active the ERV Controller.

Sensor Remote Power

+24VDC Pin 3 of TB2 and GND Pin 4 of TB2 is available for source powering sensors. (Maximum 100ma).

Frost Control

Extremely cold outdoor air temperatures can cause moisture condensation and frosting on the energy recovery wheel. Frost Control timer is a selectable timer control that will prevent control wheel frosting. Frost control uses a Therm-O-Disc P/N: 314886 T-O-D 60T11 (L15-10F) mounted in the outdoor air intake compartment. Thermo-O-Disc has pre-set temperature of 5°F and uses the normally closed contacts; contacts open on temperature rise. Use the test procedure for troubleshooting.

Remote Thermostat/Therm-O Disc Input:

Wire between Pins 5 and 6 of TB2.

Timer Settings:

T1 ON Timer	T2 OFF Timer
0 = 5 MIIN	0 = 5 MIN (default)
1 = 10 MIN	1 = 10 MIN
2 = 15 MIN	2 = 15 MIN
3 = 20 MIN	3 = 20 MIN
4 = 25 MIN	4 = 25 MIN
5 = 30 MIN (default)	5 = 30 MIN
6 = 35 MIN	6 = 35 MIN
7 = 40 MIN	7 = 40 MIN

Single Mode Speed Control

Place SW2 slide switch on ERV PCB to the Single position. Provide a 0- 10Vdc command signal to Pin 7 (-) and Pin 8 (+) of TB2. This will control the speed of both A and B motors.

Dual Mode Speed Control

Place SW2 slide switch on ERV PCB to the dual mode. Provide a 0-10Vdc command signal to Pin 7 (-) and Pin 8 (+), of TB2 for speed control of Motor A. Provide another 0-10V command signal to Pin 9 (-) and Pin 10 (+) of TB2 for speed control of Motor B.

Inlet/Outlet Motor Swap

In the event the Inlet and Exhaust vents are swapped, slide SW1 switch on ERV PCB A and B motors to reverse.

Agency Approval: UL E479135

Conditions of Acceptability

1. ERV Controller must be mounted in a suitable end-use enclosure.
2. Load motors rated 3/4HP shall be R/C (XDNW2) Electronically Protected Motor with Locked Rotor Protection.

Operation

IMPORTANT: Ensure all wiring is complete before applying power to the ERV controller.

Check Voltage

Before starting the ERV Controller, compare the supplied voltage with the unit's nameplate voltage and the motor voltage.

Initial Setup

1. Apply power to the ERV controller.
2. Remote ON: To turn "ON" the ERV Controller, provide a close contact between Pins 1 and 2 of TB2 on ERV PCB. The Green LED will illuminate when activated {"ON"}
3. Validate Motor operation: With Remote "ON" activated, verify Energy Wheel, Inlet and Exhaust motors are functioning.
Note: If A or B motor is "OFF", check the following:
 - a. Frost control maybe activated depending on the Thermostat input Pins 5 and 6 of TB2.
 - b. 0-10Vdc Speed Controls settings are too low. From 0-1.9V, the A and B motor(s) will be off and will operate within the 2-10V range.
4. Validate Inlet and Outlet (Exhaust) motor operation with setting of SW1 on the ERV Controller. Make sure SW1 is in the correct position A or B. If the Inlet and Outlet (Exhaust) are reserved, simply slide SW1 switch on the ERV PCB to the opposite position. This will swap Inlet and Outlet motors without re-wiring.
5. If +24Vdc is required for Remote sensor power, , validate +24Vdc between Pins 3 and Pin 4 (GND) of TB2. (Maximum 100ma).

HOA Troubleshooting

387192 ERV Troubleshooting Guide		
Symptoms	Potential Issues	Fix
Unit is NOT operating	<ul style="list-style-type: none"> √ Loss of Input Power √ Incorrect wiring √ Green LED is not illuminated for Remote ON √ No contact closure between Pins 1 & 2 of TB2 for Remote "ON" 	<ul style="list-style-type: none"> √ Check Breaker √ Check input power Wiring √ Validate correct Input Power to Terminal Block TB1 √ Validate a short between Pins 1 & 2 of TB2 for Remote "ON" √ Validate Green LED is illuminated for Remote ON
Energy Wheel Motor does not turn ON	<ul style="list-style-type: none"> √ No contact closure between Pins 1 & 2 of TB2 for Remote "ON" √ Validate Motor wiring to W5 and W6 (1/4") Spade Faston tabs on ERV Controller 	<ul style="list-style-type: none"> √ Validate Motor Wiring √ Validate Green LED on ERV Controller is illuminated "ON" √ Energy Wheel is stuck and is not free. Turn the energy recovery wheel by hand to verify free operation √ Replace motor
A Motor does not turn ON	<ul style="list-style-type: none"> √ No contact closure between Pins 1 & 2 of TB2 for Remote "ON" √ Validate Motor wiring to W3 and W4 (1/4") Spade Faston tabs on ERV Controller √ Validate speed potentiometer is above > 2.0Vdc 	<ul style="list-style-type: none"> √ Validate Motor Wiring √ Validate 0-10V Motor command Voltage at Motor. Motor command voltage must be > than 2.00V √ Validate Frost control is not activated. Check SW1 Inlet/Outlet switch
B Motor does not turn ON	<ul style="list-style-type: none"> √ No contact closure between Pins 1 & 2 of TB2 for Remote "ON" √ Validate Motor wiring to W1 and W2 (1/4") Spade Faston tabs on ERV Controller √ Validate speed potentiometer is above > 2.0Vdc 	<ul style="list-style-type: none"> √ Validate Motor Wiring √ Validate 0-10V Motor command Voltage at Motor. Motor command voltage must be > than 2.00V √ Validate Frost control is not activated. Check SW1 Inlet/Outlet switch
No Frost Control	<ul style="list-style-type: none"> √ Validate Thermostat Wiring Pins 5 and 6 of TB2 √ Validate Blue LED is Illuminated √ Inlet and Exhaust vents are swapped simply slide SW1 switch on ERV PCB A and B motors to reverse setting 	<ul style="list-style-type: none"> √ Validate Frost control is not activated. √ Validate SW1 Inlet/Outlet switch is set correctly. √ Validate Timers T1 and T2 for correct settings.
No remote +24V Sensor Power	<ul style="list-style-type: none"> √ Check wiring to Pins 3 and 4 of TB2. √ Measure Voltage at Pins 3 and 4 of TB2 for +24Vdc 	<ul style="list-style-type: none"> √ Check input power Wiring √ Validate correct Input Power to Terminal Block TB1 √ Remove wires at Pins 3 and 4 of TB2 and measure the voltage for +24Vdc. If +24Vdc is measured, there is too much current draw (sensor can be damaged or drawing too much power) Check Breaker

Maintenance Log

Date _____ Time _____ AM/PM

Notes: _____

Date _____ Time _____ AM/PM

Notes: _____

Date _____ Time _____ AM/PM

Notes: _____

Date _____ Time _____ AM/PM

Notes: _____

Date _____ Time _____ AM/PM

Notes: _____

Date _____ Time _____ AM/PM

Notes: _____

Date _____ Time _____ AM/PM

Notes: _____

Date _____ Time _____ AM/PM

Notes: _____

Contact Us

Technical Support and Service

800-789-8550

support@doas.com

Valent Dedicated Outdoor Air Systems

60-28th Avenue North

Minneapolis, MN 55411

Main: 612-877-4800

More Information

Unit Schematics

For configuration and connection questions, see the schematics that shipped with your unit. They can typically be found attached to the main control panel door.

Mechanical and Controls Manuals

Find current mechanical and controls manuals here: www.valentair.com/resources



OUTDOOR AIR EXPERTS
ROBUST DESIGNS
DEDICATED SUPPORT

valentair.com

© 2023 Valent

Continuous product improvement is a policy of Valent; therefore, product functionality and specifications are subject to change without notice. For the most recent product information visit the product website.

ERV Controller Manual
Part number: 486439
Rev. 1
November 2023